

A NEW ELECTRIC MOTOR CIRCUIT AND CONTROL TECHNOLOGY MULTIPLIES THE EXPECTED PRICE-PERFORMANCE GAIN OF APPLLYING WIDE-BANDGAP SEMICONDUCTORS

ABSTRACT

Wide Bandgap semiconductors (**WBG**) transistors, such as Silicon Carbide (SiC) or Gallium Nitride (GAN) transistors, have better junction performance than traditional Silicon transistors. In particular, expensive WBG transistors are being quickly adopted in electric vehicle propulsion systems, which is always the traditional electric machine circuit and control architecture with the “asymmetry” of a “passive rotor assembly” of rare-earth permanent magnets (RE-PM), slip-induction dependent windings, reluctance saliencies, or DC field windings. Instead, there is a new electric machine circuit and control technology that realizes a practical brushless, symmetrical multiphase wound-rotor “synchronous” doubly-fed electric machine system, as only possible with the patented [SYNCHRO-SYM](#), which includes the enabling invention of a brushless real time emulation controller (**BRTEC**) for contiguously stable operation from sub-synchronous to super-synchronous speed, which was postulated during the last half century of classic electric machine study. This study will show the circuit and control technology of SYNCHRO-SYM provides six times the expected performance gains while nearly halving the expected cost when applying wide-bandgap semiconductor (**WBG**) technology to the traditional electric machine circuit and control architecture.

Introduction

Wide Bandgap semiconductors (**WBG**), such as Silicon Carbide (SiC) or Gallium Nitride (GAN) transistors, have better junction performance than traditional Silicon transistors. In particular, expensive WBG transistors are being quickly adopted in electric vehicle propulsion systems, which is always the traditional asymmetric electric motor or generator (i.e., electric machine) circuit and control architecture with the “asymmetry” of a “passive rotor assembly” of rare-earth permanent magnets (RE-PM), slip-induction dependent windings, reluctance saliencies, or DC field windings and an active stator assembly with a directly-excited multiphase winding set (i.e., “active winding sets”) under a derivative of field oriented control (FOC). Instead, there is a new symmetric electric machine circuit and control technology that realizes a practical brushless, symmetrical multiphase wound-rotor “synchronous” doubly-fed electric machine system, as only provided by [SYNCHRO-SYM](#), with the symmetry of two “active winding sets” on the rotor and stator assemblies, respectively, which is only possible by the enabling invention of a brushless real time emulation controller (**BRTEC**) for contiguously stable operation with twice the power density, octuple the peak torque, half the cost, and half the loss per unit of continuous power rating as the asymmetric electric machine system, as postulated during the last half century of classic electric machine study. This study will show the symmetric electric machine circuit and control technology of SYNCHRO-SYM provides six times the expected performance gains while nearly halving the expected cost when applying wide-bandgap semiconductor (**WBG**) technology to the traditional electric machine circuit and control architecture.

Electronic Power Transfer Effectiveness:

For the purpose of this discussion, there are three *basic* power converter circuit topologies for controlling *bidirectional power* to a three phase electric machine system: a) the [TOTEM Pole Converter](#), which is with the loss, cost, and size of a DC Link Stage for waveform smoothing and power ballast, b) the [Matrix Converter](#), which is without a DC Link Stage but with the loss, cost, and size of low frequency line chokes for waveform smoothing, and c) the High Frequency Half or Full Bridge Converter, which requires one instance per phase for controlling an electric machine system, is common to the [solid-state electronic transformer \(SST\)](#), and is with the loss, cost, and size of a high frequency transformer for waveform smoothing and power ballast instead of a DC Link stage.

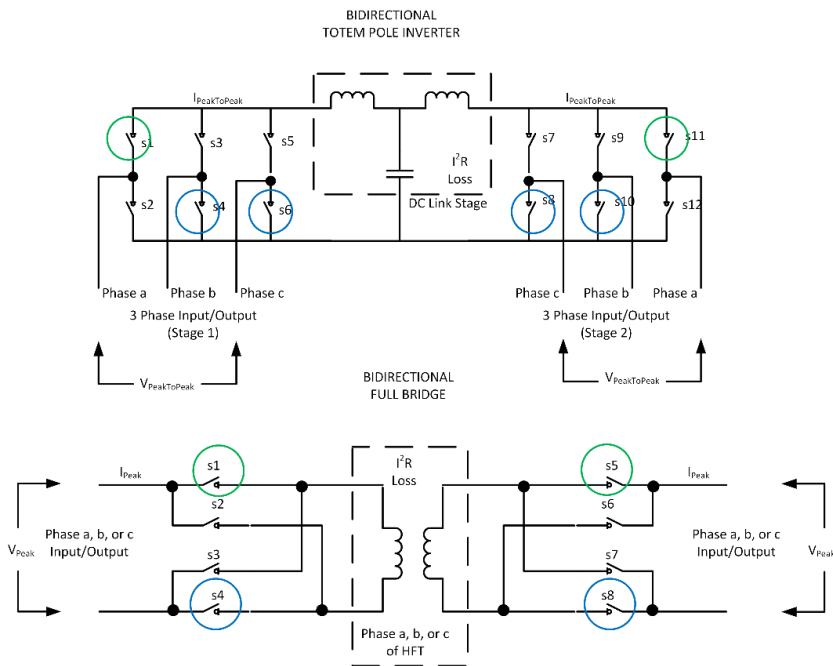

Figure 1

For controlling *symmetrical bi-directional* power transfer and control, all active switches must be bi-directional switches, which today is configured with two back-to-back unidirectional switches. Figure 1 shows examples of the *symmetrically bi-directional* TOTEM Pole Converter, which is common to the Field Oriented Controller (FOC) of the common asymmetric electric machine system, and the high frequency Full Bridge Converters, which is particularly common to the BRTEC of SYNCHRO-SYM. Refer online for examples of the [Matrix Converter](#).

Note: Whether a multiphase AC source or a DC source, such as an EV battery, there must be a means to regulate the DC Link Stage of the Bi-directional TOTEM Pole Converter. In practice, this is done with extra circuitry, such as a choke and switches to actively control the DC Link stage voltage. For the simplicity of this discussion, all three phases of one stage of the TOTEM Pole will be connected to the DC sources and the switch modulation of that stage (with the choke of the DC link Stage) will actively regulate the DC Link Stage voltage, which may not be the most optimal configuration.

There are three basic families of active (i.e., gate controllable) power semiconductor switches (i.e., transistor): a) the Field Effect Transistor (FET), such as power MOS-FETs, b) the Bipolar Transistor (BPT), and c) the IGBT, which is a hybrid FET/BPT. The *electrical loss* of the BPT depends on the product of the diode junction drop (V_D), which effectively remains constant with increasing current, and the current through the junction (I). In contrast, the *electrical loss* of a FET depends on the product of the junction current squared (I^2) and the resistance of the junction (R_J). It is reasonable to assume active switch cost is directly proportional to its power rating within the same family as verified in at least sales catalogues. Wide-Bandgap semiconductors (**WBG**), such as Silicon Carbide (SiC) or

Gallium Nitride (GAN), have better junction performance than traditional Silicon semiconductors, particularly for the FET family.

NOTE: An analytical proof requires pertinent components of the evaluation are normalized to units with reasonable cost, loss and size relationships (e.g., \$/KW, loss/KW, size/KW), which can be used for all electronic controllers, regardless of type. Also, an active switch is functionally enabled by the gate drive circuitry and as a result, the so-called normalized “active switch” used in this analysis includes the normalized portion of the circuitry and components per active switch, such as gate drivers, that functionally enables the active switch.

The **COMPONENT TYPE AND COUNT TABLE** shows the total active switch count for bi-directional power control: 1) the asymmetrically bidirectional TOTEM Pole Converter with uncontrollable diode rectifiers in place of active switches is shown for comparative convenience but is

not considered a viable performance contender because of distorted waveforms and as a result, it will not be used in the analysis, 2) the symmetrical bidirectional TOTEM Pole Converter, 3) Matrix Converter, 4) the Full Bridge Converter of the BRTEC of SYNCHRO-SYM, and 5) the Full Bridge Converter of the BRTEC for the rotor and stator active winding sets of SYNCHRO-SYM or Dual BRTEC.

The Power Transfer Effectiveness of the circuit topologies depends on the following:

(A) *Power Transfer Effectiveness:*

For the symmetrically bidirectional three phase AC to three phase AC power conversion transfer effectiveness, all switches of the 3-

phase TOTEM Pole Converter (or the [Matrix Converter](#)) are connected across all phases of the 3 Phase AC power source (and the DC Link Stage) and as a result, the active switches must support: a) the Peak-To-Peak AC voltage (i.e., $V_{PeakToPeak} = 1.73 \times V_{Peak}$), where V_{Peak} is the peak voltage of a single AC phase, b) the Peak-To-Peak AC Current (i.e., $I_{PeakToPeak} = 1.73 \times I_{Peak}$), and c) the Peak-To-Peak Power ($V_{PeakToPeak} \times I_{PeakToPeak} = 3 \times V_{Peak} \times I_{Peak}$) to control an electric motor (with a Wye or Delta winding arrangement). *Note: Not considered in this simple analysis, the AC ripple within the DC Link stage of the TOTEM Pole Converter topology could show at least another 20% reduction in voltage*

COMPONENT TYPE AND COUNT TABLE			
Power Conversion Type	Number of symmetrically bi-directional switches	Number of Configured Unidirectional Switches	Link Stages
Asymmetrical TOTEM Pole Converter	N.A.	12	DC Link Stage
Symmetrical TOTEM Pole Converter	12	24	DC Link Stage
Matrix Converter	9	18	Low Frequency Input Chokes
Full Bridge SYNCHRO-SYM BRTEC	24	48	PDF-HFT
Full Bridge SYNCHRO-SYM or Dual BRTEC	48	96	Modified PDF-HFT

transfer due to the 6 pulse rectification stage.¹ In contrast, all switches of the High Frequency Full Bridge Converter are connected across a single phase of the three phase power source and as a result, the switches only support: a) the Peak AC Voltage (i.e., $V_{Peak} = (V_{PeakToPeak})/1.73$), b) the Peak AC Current (i.e., $I_{Peak} = (I_{PeakToPeak})/1.73$), and c) the Peak Power (i.e., $V_{Peak} \times I_{Peak} = V_{PeakToPeak}/3$) of each phase winding of the motor with the total peak power to the motor ($V_{PeakToPeak} \times I_{PeakToPeak} = 3 \times V_{Peak} \times I_{Peak}$) supplied by three independent phase leg circuits.

In summary for the normalized symmetrically bidirectional three phase AC to three phase AC power conversion transfer effectiveness with cost directly proportional to power rating, the BPT active switches of the High Frequency Full Bridge Converter have a normalized 3x Cost advantage (and a normalized 1.73x Electrical Loss) advantage over the BPT active switches of the TOTEM Pole Converter or the Matrix Converter because of the 3x power transfer advantage and the 1.73x current transfer advantage but the FET active switches of the High Frequency Full Bridge Converter have the same 3x Cost advantage but also, a 3x Electrical Loss advantage because of the FET's I^2R Loss ($(V_{PeakToPeak}/1.73)^2$) over the virtually fixed diode junction drop Loss of the BPT.

For the symmetrically bidirectional DC to three phase AC power conversion transfer effectiveness, such as an electric vehicle (EV) battery supplying a voltage of V_{DC} , all active switches of the TOTEM Pole Converter or the Matrix Converter are across the DC Link voltage (V_{DC}) or $V_{DC} = V_{PeakToPeak}$ and as a result, all active switches must be rated for V_{DC} or $V_{PeakToPeak}$. Considering a wye motor winding arrangement and neglecting loss, the peak AC voltage (V_{Peak}) transfer to each phase winding leg is ($V_{PeakToPeak} / 1.73 = V_{DC}/1.73 = V_{Peak}$), the RMS power transfer from the DC link stage to each AC phase winding leg of the motor is $((V_{PeakToPeak} / 1.73)/2^{1/2})^2/L = (V_{DC})^2/(3*2*L)$, where L is the Mechanical Load of the motor, and the RMS power transfer to all three AC phases of the motor is $(3*((V_{DC})^2/(3*2*L))) = (V_{DC})^2/(2*L)$. The active switches of the High Frequency Full Bridge Converter must also support $V_{Peak} = V_{DC}$ but because of independent converters per phase winding leg, the effective RMS power transfer to each AC phase winding of a wye electric motor with the same Mechanical Load, L, is $((V_{Peak})/2^{1/2})^2/L = (V_{DC})^2/(2*L)$ and the total RMS power transferred to all three phases is $(3*((V_{DC})^2/(2*L)))$. Although all active switches of the High Frequency Full Bridge Converter, the TOTEM Pole Converter, or the Matrix Converter are rated for V_{DC} , the power transfer effectiveness between the semiconductors of High Frequency Full Bridge Converter, which is directly powering each phase, over the TOTEM Pole or Matrix Converters, which is directly powering 2 phase windings, is 3x or $(3*((V_{DC})^2/(2*L))) \div ((V_{DC})^2/(2*L))$. As a result of the same port voltage, the DC Link Stage reactive components and at least one active switches of TOTEM Pole or the Matrix Converter at an instance of time must support 3x the peak current compared to the active switches for High Frequency Full Bridge Converter.

In summary for the normalized symmetrically bidirectional DC to three phase AC power conversion transfer effectiveness with costs directly proportional to power rating, the BPT active switches of the High Frequency Full Bridge Converter have a 3x normalized cost (and a 3x normalized loss) advantage over the BPT active switches of the TOTEM Pole Converter or the Matrix Converter because of the 3x

¹ 1.65 is a constant, which gives the average DC voltage or current when multiplied by the Effective Line (phase to phase) voltage or current for a 3 phase, six pulse, 6 device Converter stage, "Electrical Power Technology," Theodore Wildi, John Wiley and Sons, 1981, page 446.

effective power transfer at the 3x effective current transfer advantage but for FET active switches, the High Frequency Full Bridge Converter has a 3x normalized cost advantage over the FET active switches of the TOTEM Pole Converter or the Matrix Converter for the same effective power transfer because cost is directly proportional to power transfer effectiveness or rating but a 9x Electrical Loss advantage because of the FET's I^2R Loss (with current/3).

(B) Duty Cycle Effectiveness:

The switches of the TOTEM Pole Converter and Matrix Converter effectively operate at 100% duty cycle, because each switch must be “on” at the Peak-to-Peak Voltage or the Peak-to-Peak Current for a long duration of time beyond their Safe Operating Area (SOA), such as $1/3^{\text{rd}}$ the sinusoidal AC modulation period (i.e., 50 or 60 Hz). In contrast with synchronous switching also providing low harmonic content, nearly pure sinusoidal wave generation, and inherent resonant (or soft) switching, the active switches of the High Frequency Full Bridge Converter, such as for BRTEC, control the voltage and currents of a single phase with a high frequency 50% duty cycle power conveniently shared between two switches for twice the thermal management effect as the 100% duty cycle switches of the TOTEM Pole Converter or Matrix Converter. Therefore, the switches can be substituted with a half current rated and proportionally half cost switches.²

In summary, the BPT or FET active switches of the high frequency Full Bridge synchronous MODEM of BRTEC will effectively have a 2x cost advantage over the BPT or FET active switches of the TOTEM Pole Converter or the Matrix Converter because the effective half duty cycle of BRTEC allows for “half current rated” (or half power rated and cost) active switches to support the same current as the TOTEM Pole Converter and the Matrix Converter. Since the BPT diode junction voltage drop changes little with current changes, the BPT loss will have no advantage, but since the half cost and current rated FET effectively doubles junction resistance, the loss advantage will halve. NOTE: The multiplying cost and loss advantages of Duty Cycle will not be used in the analysis.

(C) Monolithic (Single Substrate) Bidirectional Switch Effectiveness:

If a monolithic (i.e., single substrate), symmetrical [bi-directional switch](#) were commercially available with comparable cost (and switch electrical loss) as a unidirectional switch, the number of switches for all controller contestants and the loss and cost would halve again. *In 2017, Fuji provided [a solid-substrate bi-directional switch](#) on the same substrate for the popular Matrix Converter, which lowered the cost, loss, and component complexity for the bi-directional switches by 2x; however, this seems to have been discontinued.* NOTE: The multiplying advantages of a single substrate Bidirectional Switch will not be used in the analysis.

(D) “On” Diode Junction Drop (BPT) or Resistance Junction Drop (FET) versus Breakdown Voltage Rating Effectiveness:

² [Application Note AN-949](#) states, “IGBTs and MOSFETs are able to carry peak current well in excess of their continuous current rating, provided the rated junction temperature is not exceeded.” Under resonant switching (sinusoidal wave) as inherently provided by BRTEC, the temperature rise of $2xI_{\text{peak}}$ (i.e., RMS is $I_{\text{peak}}/2^{1/2}$) at 50% duty is effectively the same as I_{peak} at 100% duty cycle (i.e., RMS is $I_{\text{peak}}/2^{1/2}$), as long as the junction temperature is held within the Safe Operating Area. Also, BRTEC shares heat dissipation between two switches for twice the thermal cooling.

In accordance to semiconductor physics, it is reasonable to assume that the [junction on resistance of a FET is proportional to its junction Breakdown Voltage rating](#). For instance, if the junction breakdown voltage of the FET doubles the junction on resistance doubles. In contrast, the diode junction drop of a BPT changes little with junction current or breakdown voltage.³

(E) SYNCHRO-SYM Performance Effectiveness:

The following bibliography references 60 years of selected academic studies (*with clarifying comments enclosed in {}*), which confirm the benefits and challenges surrounding the hypothetical brushless symmetric multiphase doubly-fed "synchronous" electric motor or generator system with directly excited multiphase winding sets (*i.e., active winding sets*) symmetrically placed on the rotor and stator assemblies to inherently maintain the same electric motor package footprint of materials, cost, and loss *but only by postulating the enabling invention of a brushless real time emulation controller (BRTEC) during its study* to eliminate: i) the reliance on slip-induction, which ceases to exist at synchronous speed, ii) the multiphase brush-slip-ring assembly, and iii) the known instability issues due to at least rotor and line perturbations while motoring or generating from sub-synchronous to super-synchronous speeds:[6]

- “The double-armature machine *{similarly known as the symmetric synchronous doubly-fed electric motor}* has many merits...**continuous power rating is double**...in addition...**a maximum pull-out torque of...eight times** nominal frame size torque rating” [See page 95, 1st column, paragraph 3] [1],
- “...the power electronic converter *{of the symmetric synchronous doubly-fed electric motor}* only has to handle a fraction of the **total power...losses in the power electronic converter can be reduced...the cost...becomes lower**” [See page 227, 1st column, paragraph 1] [2],
- “...the **doubly-fed synchronous** electric machine *{of the symmetric synchronous doubly-fed electric motor}*...which allows full advantage...from the possibility of delivering energy to both the rotor and stator...create unstable operation...” [See page 653, 1st column, paragraph 1] [3],
- “The **operation of an ideal control circuit would be independent of the amplitude and frequency of the input signal** *{emulation}*” [See page 656 3rd column paragraph 1] [3], “The **controller requires too many measurements and off-line computations**... *{not automatic, sensorless, real time}*” [See page 1651, 1st column, paragraph 3] [4],
- “...**realization of such a control which requires...zero time**...” [See page 803 paragraph 6] [5].

Caveat: Never realizing the enabling BRTEC invention (until SYNCHRO-SYM), the brushless symmetric multiphase wound-rotor *synchronous* doubly-fed EMS is always mistakenly confused with the antiquated asymmetric multiphase wound-rotor *asynchronous* (i.e., induction) doubly-fed EMS with the asymmetry of a passive rotor of slip-induction dependent windings, which is with the size, cost, loss, and reliability issues of a multiphase slip-ring assembly for electrical power connection to the rotor active winding set and the instability issues associated with the loss of slip-induction *about*

³ [Application Note AN-7244](#): Two conclusions, inherent consequences of the laws of semiconductor physics, and valid for any DMOS device, can be drawn from the preceding discussion: First, $r_{DS(ON)}$ obviously increases with increasing breakdown-voltage capability of MOSFET. Second, minimum $r_{DS(ON)}$ performance must be sacrificed if the MOSFET must withstand ever-higher breakdown voltages.

synchronous speed and the positive feedback of line or rotor shaft perturbations that were understood to only be resolved by applying the formidable invention of a brushless real time emulation controller.

In summary, *the brushless symmetric multiphase wound-rotor synchronous doubly-fed electric motor, now called **SYNCHRO-SYM***, provides double constant-torque speed range (i.e., *Maximum Load Speed or MLS*) for a given *continuous* torque, excitation frequency, port voltage, air-gap flux density, and electric motor package footprint of materials, cost, and loss (e.g., *7200 RPM with 1 pole-pair @ 60 Hz of excitation versus 3600 RPM for all others*), which is unquestionably tantamount to twice the power density (and octuple the peak torque for gearless EVs) at half the cost and half the loss *per unit of continuous power rating* of all other electric machine systems by reasonably assuming the rotor and stator consume similar real-estate, loss, and cost by combining the compounding effects of friction and electronic control. Since SYNCHRO-SYM effectively shares the total active current evenly between rotor and stator *ports* with the same port voltage (i.e., doubly-fed) for twice the power, BRTEC need only support half the current for a given power rating, voltage, excitation frequency, air-gap flux density, constant torque speed range, and torque compared to controlling the full current of the conventional electric motor system with the TOTEM Pole Converter or the Matrix Converter.

Therefore, the BPT active switches of BRTEC for SYNCHRO-SYM have an effective 2x Cost and a 2x Electrical Loss (e.g., I^2R) advantage over the BPT active switches of the TOTEM Pole Converter or

BRTEC COST & LOSS ADVANTAGE MULTIPLIER TABLE								
	[3 Phase AC to 3 Phase AC Conversion]				[DC (e.g., EV Battery) to 3 Phase AC Conversion]			
	BPT		FET		BPT		FET	
Power Transfer Effectiveness	Cost factor (Voltage x Current)	Loss factor (Current x diode Junction Drop)	Cost factor (Voltage x Current)	Loss factor (Current ² x R Drop)	Cost factor (Voltage x Current)	Loss factor (Current x diode Junction Drop)	Cost factor (Voltage x Current)	Loss factor (Current ² x R Drop)
(A) Power Transfer	3	1.73	3	3	3	3	3	9
(B) Duty Cycle	2	1 (N.A.)	2	1/2	2	1 (N.A.)	2	1/2
(C) Monolithic Bidirectional Switch	2	2	2	2	2	2	2	2
(D) Junction Drop	N.A.	N.A.	1	1.73 ¹	N.A.	N.A.	1	1 ²

(E) SYNCHRO-SYM Performance	2	2	2	4	2	2	2	4
BRTEC Advantage Multiplier	6	3.46	6	20.76	6	6	6	36

¹ The FET rated breakdown voltage of the BRTEC 3 Phase AC to AC full bridge converter only is $V_{Peak} = (V_{PeakToPeak})/1.73$ and as a result, the lower voltage rate FET will reasonably show $RDS/1.73$ or a 1.73 multiplier.
² The FET rated breakdown voltage of the BRTEC DC to 3-Phase AC full bridge converter is rated at the same voltage $V_{Peak} = (VDC)$.

the Matrix Converter. Likewise with half the current transfer for a given port voltage, the FET active switches of BRTEC have a 2x Cost (and a 4x Electrical Loss) advantage over the FET active switches of the TOTEM Pole Converter and the Matrix Converter.

The green row of the **BRTEC COST & LOSS ADVANTAGE MULTIPLIER TABLE** summarizes the *compounded* loss and cost advantage multipliers for BRTEC versus the TOTEM Pole and Matrix Converters.

RELATIVE ELECTRONIC CONTROLLER <u>BPT & FET</u> SWITCH COST & LOSS COMPARISON TABLE^{2,3}					
	3-Phase AC to 3-Phase AC		DC to 3-Phase AC		(+) Link Stage
Power Conversion Type (unidirectional switch count) ["on" switch drop count]	Normalized Effective Switch <u>Loss</u>	Normalized Effective Switch <u>Cost</u>	Normalized Effective Switch <u>Loss</u>	Normalized Effective Switch <u>Cost</u>	I^2R Loss & Cost
	BPT (FET)	BPT (FET)	BPT (FET)	BPT (FET)	
BRTEC (48 switches) [24 drops]	6.9 (1.2)	8 (8)	4 (0.67)	8 (8)	PDF-HFT ¹ 0.1
Dual BRTEC (96 switches) [48 drops]	13.9 (2.3)	16 (16)	8 (1.33)	16 (16)	PDF-HFT ¹ 0.2
Matrix Converter (18 switches) [4 drops]	4 (4)	18 (18)	4 (4)	18 (18)	Low Frequency Supply Line Chokes ¹ 0.5

Asymmetric TOTEM Pole Converter (12 switches) [4 drops]	4 (4)	12 (12)	4 (4)	12 (12)	DC Link Stage ¹ 1
Symmetric TOTEM Pole Converter (24 switches) [8 drops]	8 (8)	24 (24)	8 (8)	24 (24)	DC Link Stage ¹ 1

¹ Because of the significantly higher operating frequency, the PDF-HFT has significantly fewer winding turns (resistance) and lower core flux density for at least a tenth of the losses of Line Chokes and DC Link Stages

² If a common substrate bi-directional switch was available, all loss and cost data would be nearly halved again with the exception of the Asymmetric TOTEM Pole Converter, which does not have traditional [bi-directional switches](#) comprising two back-to-back unidirectional switches.

³ Compounding cost and loss of the electric machine entity is not included.

EFFECTIVE ACTIVE SWITCH COST and LOSS COMPARISON:

The green and blue circled switches in Figure 1 show the “on switches” in the conduction path at a given “on” instance in time. The electrical loss is determined by the current through the total “on” active switch junction drops in the conduction path. As shown in column one of the **RELATIVE**

RELATIVE ELECTRONIC CONTROLLER <u>Wide Bandgap (WBG)</u> FET SWITCH COST & LOSS COMPARISON TABLE^{2,3}					
	3-Phase AC to 3-Phase AC		DC to 3-Phase AC		(+) Link Stage
Power Conversion Type (unidirectional switch count) [“on” switch drop count]	Normalized Effective Switch <u>Loss</u>	Normalized Effective Switch <u>Cost</u>	Normalized Effective Switch <u>Loss</u>	Normalized Effective Switch <u>Cost</u>	I ² R Loss & Cost
BRTEC (48 switches) [24 drops]	1.2	8	0.67	8	PDF-HFT ¹ 0.1
Dual BRTEC (96 switches) [48 drops]	2.3	16	1.33	16	PDF-HFT ¹ 0.2
Matrix Converter (18 switches) [4 drops]	4	18	4	18	Low Frequency Supply Line Chokes ¹

					0.5
Asymmetric TOTEM Pole Converter (12 switches) [4 drops]	4	12	4	12	DC Link Stage ¹ 1
Symmetric TOTEM Pole Converter (24 switches) [8 drops]	8	24	8	24	DC Link Stage ¹ 1
Dual BRTEC advantage multiplier	3.5x	1.5x	6x	1.5x	

¹ Because of the significantly higher operating frequency, the PDF-HFT has significantly fewer winding turns (resistance) and lower core flux density for at least a tenth of the losses of Line Chokes and DC Link Stages

² If a common substrate bi-directional switch was available, all loss and cost data would be nearly halved, with the exception of the Asymmetric TOTEM Pole Converter, which does not have traditional [bi-directional switches](#) comprising two back-to-back unidirectional switches.

³ Compounding cost and loss of the electric machine entity is not included.

ELECTRONIC CONTROLLER BPT & FET SWITCH COST & LOSS COMPARISON

TABLE, the number of “active switch for “on” switch power transfer is effectively: a) four “on” bidirectional switches (*i.e.*, 8 “on” unidirectional switches) for the symmetrically bidirectional

TOTEM Pole Converter, b) four “on” unidirectional switches for the *asymmetrically bidirectional* TOTEM Pole Converter, c) two “on” bidirectional switches (*i.e.*, 4 “on” unidirectional switches) for the MATRIX Converter, d) four “on” bidirectional switches per phase (*i.e.*, 8 “on” unidirectional switches) for the FULL BRIDGE Converter (*i.e.*, 24 “on” unidirectional switches for all three phases of the single BRTEC configuration and 48 “on” unidirectional switches for the dual BRTEC configuration with one BRTEC per port).

The **RELATIVE ELECTRONIC CONTROLLER BPT & FET SWITCH COST & LOSS COMPARISON TABLE** shows the *effective* cost and electrical loss between the four control circuit topologies by simply dividing the BRTEC total number of active switches (drops and cost) by the appropriate cost and loss advantage multiplier from the **BRTEC COST & LOSS ADVANTAGE MULTIPLIER TABLE**. For instance, the first column of the **RELATIVE ELECTRONIC CONTROLLER BPT & FET SWITCH COST & LOSS COMPARISON TABLE** shows BRTEC has the cost of 48 unidirectional active switch drops and costs but has an *effective* BPT(FET) active switch cost of actually 8(8) active switches after dividing by the cost advantage multiplier of 6 from the **BRTEC COST & LOSS ADVANTAGE MULTIPLIER TABLE** for a DC to three Phase AC Conversion.

After condensing the **RELATIVE ELECTRONIC CONTROLLER BPT & FET SWITCH COST & LOSS COMPARISON TABLE** for WBG FET active switches, the WBG FET results are in the **RELATIVE ELECTRONIC CONTROLLER Wide Bandgap (WBG) FET SWITCH COST & LOSS COMPARISON TABLE**.

NOTE: The analysis reasonably considered that active switches consume the major loss and cost of any controller. The cost and loss did not analytically include the glue components, such as drivers, reactive components, such as chokes and capacitors, which consume similar cost and loss amongst all electronic controllers.

CONCLUSION:

Today, electric vehicle motor controllers and battery chargers are quickly moving towards SiC or GAN WBG FET power semiconductors because of their higher operating temperature, faster switching speeds, and significantly lower “on” junction resistance compared to conventional silicon substrate switches. Simple analysis summarized in the **RELATIVE ELECTRONIC CONTROLLER Wide Bandgap (WBG) FET SWITCH COST & LOSS COMPARISON TABLE** shows the dual BRTEC circuit and control topology of SYNCHRO-SYM will *significantly* improve the expected performance gain of the **WBG FET switch** over the symmetrically bidirectional converters for the traditional electric vehicle (DC battery supply) electric machine system with a passive rotor of RE-PMs, slip-induction dependent windings, reluctance saliencies, or DC field windings **with at least a 1.5x lower effective switch cost and a 6x lower effective electrical loss** without considering other advantages of BRTEC, such half duty cycle switching.

Although the number of active switches of BRTEC may seem complex without considering contemporary automated assembly and consolidate packaging techniques, the normalized effective cost (or count) and electrical loss of the BRTEC active switches, which is a major cost, are significantly lower than the TOTEM Pole Converter or Matrix Converter after dividing by the BRTEC advantage multiplier from the **RELATIVE ELECTRONIC CONTROLLER Wide Bandgap (WBG) FET SWITCH COST & LOSS COMPARISON TABLE**. In addition, BRTEC loss and cost analysis is without the loss, cost, and size of the large, lossy DC Link Stage or Line reactors associated with the TOTEM Pole Converter or Matrix Converter, which introduces significant *compounding* size, loss and cost over the BRTEC circuit and control topology. Since the electronic controller also controls the loss of the motor, the losses and costs pass through the controller and as a result, are “compounded.” For instance, if the controller is 90% efficient (10% of the controller power is loss) and the motor is also 90% (10% of the motor power is loss), the total efficiency of the “system” is the product of the motor and controller efficiencies or 81% (90% * 90%).

As only available in [SYNCHRO-SYM](#), which is a brushless symmetric wound-rotor “synchronous” doubly-fed electric machine system, and without introducing the additional compounding cost and loss of the electric machine entity, the **Brushless Real Time Emulation Controller (BRTEC)** shows less than half the cost and loss of any state-of-art Field-Oriented Controller (FOC) of all other electric machine systems with a passive rotor of slip-induction dependent windings, DC field windings, reluctance saliencies, or rare earth permanent magnets.

References

- [1] W. F. Long and N. L. Schmitz, "Cycloconverter Control of the Doubly-fed Induction Motor," IEEE Transactions on Industry and General Applications, Vol. IGA-7, No. 1, January/February 1971, Page 95-99.
- [2] A. Petersson, L. Harnefors, and T. Thiringer, "Evaluation of Current Control Methods for Wind Turbines Using Doubly-Fed Induction Machines," IEEE Transactions On Power Electronics, Vol. 20, No. 1, January 2005, pp. 227-235.
- [3] D. W. Novotny and N. L. Schmitz, "Parametric Pump-Down of Synchronous Machine Oscillations," AIEE Great Lakes District Meeting, Fort Wayne, Ind., April 25-27, 1962. Page 652-657.
- [4] Y.L. Abdel-Magid, A. H. M. A. Rahim, M. A. Al-Yadoumi, "A Quasi-optimal Stabilizing Control of Power Systems With Dual-Excited Machines," 1991 IEEE Industry Applications Society Annual Meeting, 28 Sept-4 Oct 1991, ISBN: 0-7803-0453-5.
- [5] A.H.M.A Rahim, "Stabilizing Controls for Doubly Fed Synchronous-Induction Machines," IEEE Transactions on Energy Conversion, Vol. 3, No. 4, December, 1988, pp. 799-803.
- [6] Frederick William Klatt, "Qualitative Analysis: Brushless Wound-Rotor [Synchronous] Doubly-Fed Electric Machine for electric propulsion," 2013 IEEE Transportation Electrification Conference and Expo (ITEC), 16-19 June, 2013.